

ASSEMBLY INSTRUCTIONS

1. TURN BASE UPSIDE DOWN
2. PLACE AXLE BETWEEN AXLE MOUNT BRACKETS AND FASTEN BRACKETS TO BASE USING (4) BOLTS, LOCKWASHERS AND NUTS PROVIDED. (USING A SHARP KNIFE OR FILE CLEAN PAINT FROM INSIDE AXLE HOLE BEFORE INSTALLING AXLE.)
3. FASTEN LEGS TO BASE USING (4) BOLTS, LOCKWASHERS, AND NUTS PROVIDED. DO NOT TIGHTEN THE NUTS SECURELY AT THIS TIME.
4. MOUNT TWO LEG SUPPORT BRACKETS TO BASE UTILIZING TWO BOLTS IN AXLE MOUNT BRACKET. (DO NOT TIGHTEN NUTS SECURELY AT THIS TIME.)
5. BOLT LEG SUPPORT BRACKET AND LEG THE STRIP TO EACH LEG USING (4) BOLTS, LOCKWASHERS, AND NUTS PROVIDED.
6. TIGHTEN ALL NUTS SECURELY AT THIS TIME.
7. PLACE A WHEEL ON EACH END OF AXLE. USE 5/18-18 HEX NUT TO HOLD WHEEL ON TO AXLE.
8. TURN CART RIGHT SIDE UP.
9. FASTEN HANDLE BAR BRACKETS AND HANDLE TO BASE USING BOLTS AND NUTS PROVIDED. (HANDLE MUST BE IN PLACE BEFORE LAST BRACKET IS BOLTED IN PLACE.)

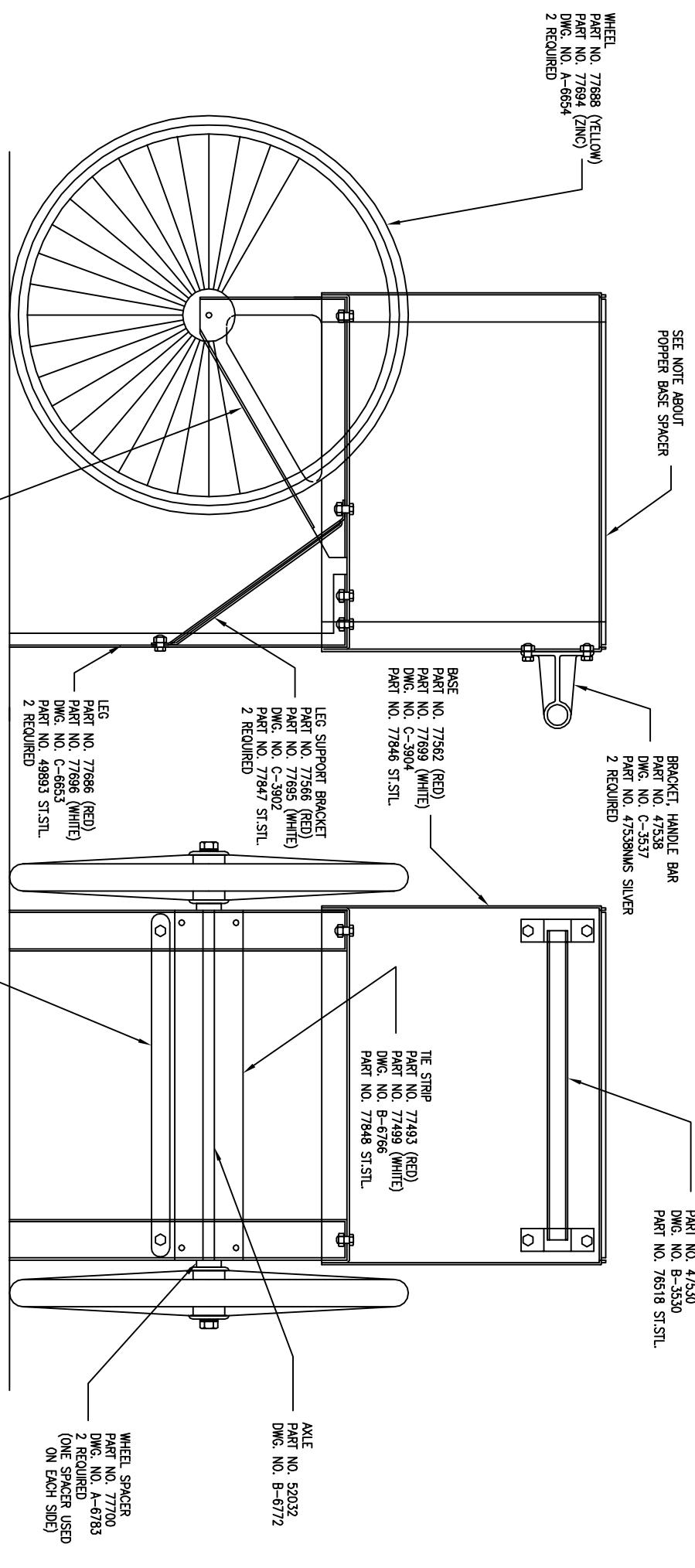

NOTE:
MODELS 2148CR AND 2148CW
ARE U.L. LISTED AS OF 12-1-89

MODEL NUMBER	CART COLOR
2148CR	RED
2148CW	WHITE
2148ST	ST.STL

SHELF OPTION #2222	SHELF OPTION #2221	SHELF OPTION #2222ST

REVISIONS		
LET	DESCRIPTION	DATE BY CAD
A	ADDED NOTE	12-1-89 MB
B	ADDED COLOR CHART	12-1-89 MB
C	REDRAWN	8-29-89 BN MD
D	ADDED 2148FW	7-27-89 MD MD
E	DELETE 2148FW	8-24-89 DEP DEP

ASSEMBLY INSTRUCTIONS

USED ON **20" 2 WHEEL CART**

DMK. ORG	DWG. NO.	DATE	SCALE	DO NOT SCALE DRAWING
		9-12-78	1/2" = 1"	

NOTE:
IF USING PORCORN MACHINES,
MODEL NO. 2660, 2660GT, OR 1871,
USE POPPER BASE SPACER PART NO.
77693, DWG. NO. C-6696.